

PARTS ASSEMBLIES FOR Bonis Models: 3051, 3051-2, 3064, 3065, 3066, 3067, 3068



CAUTION: Order by part number only. When ordering parts, kindly state
Serial and Model Numbers of Machine.

The Serial Number is stamped on the back of the main frame.
The Model Number is printed on name plate on left side.

BONIS BROS. SEWING MACHINERY CORP.

111 West 26th Street, New York, N.Y. 10001 • Phone 212/645-0001

Cable Address: "BONIBRO"

Telex: 422449

Fax: (212)645-0914

MAIN FRAME ASSEMBLY

Fig. 1

PART NO.	DESCRIPTION
3002	MAIN FRAME, "51" CLASS
3026	BACK COVER
3028	BACK COVER GASKET
3060	OIL PUMP ASSEMBLY
3068	OIL MANIFOLD ASSEMBLY
3517	OIL SEAL WASHER, LARGE
3575	OIL TUBE
3751	FEED SHAFT NUT
3755	BACK COVER SCREWS
3756	OIL MANIFOLD SCREW
3758	DRAIN CAP
3760	FEED GEAR SHAFT SCREW
3763	GEAR PUMP SET SCREW

PARTS ASSEMBLIES F
Bonis Models: 3051, 3051-
3065, 3066, 3067, 306

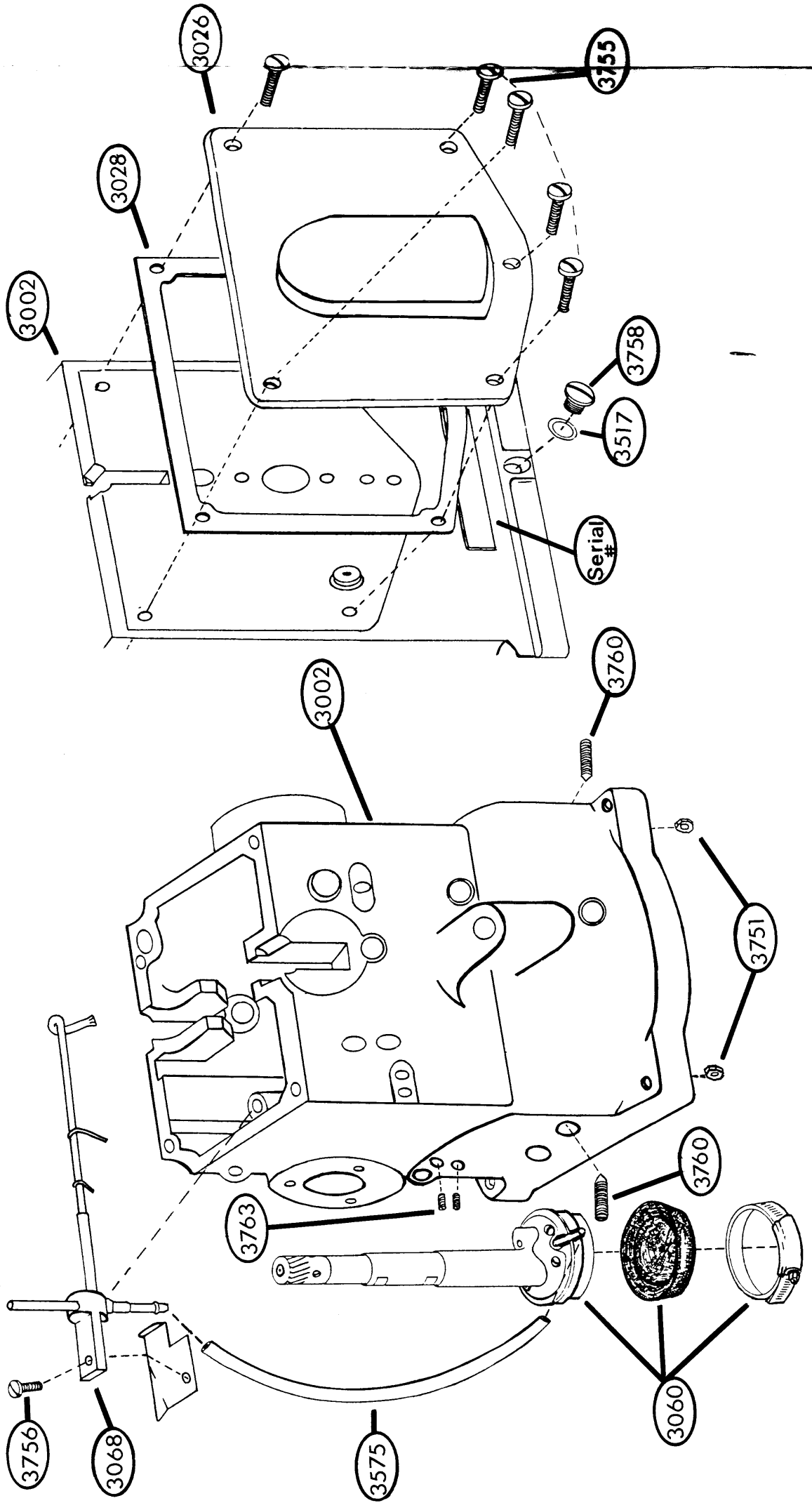

Fig. 1

LOOPER FRAME ASSEMBLY

Fig. 3

PART NO. DESCRIPTION

27	BALANCE WEIGHT
114-BB-2	.	TWO THREAD LOOPER (FOR 3051-2 ONLY)
114-TT	...	LOOPER
126	LOOPER CAM ROLLER
143	ROCKER PACKING (Specify Thickness: .004, .006, .010, .020)
144-T	LOOPER FRAME
149-T	OSCILLATING CAM
202	ECCENTRIC SET SCREW, 2 REQ'D
207	LOOPER CAM ROLLER STUD
208	LOOPER CAM ROLLER STUD SET SCREW
214	BALANCE WEIGHT SCREW, 2 REQ'D
234	LOOPER ECCENTRIC PIN
411-51	...	LOOPER FRAME ECCENTRIC
609	LOOPER OSCILLATING ARM
639	LOOPER OSCILLATING ARM PINCH SCREW, 2 REQ'D
3010-51	..	BACK ROCKER, COMPLETE "51" CLASS
3121	BELLOWS TYE
3122	BELLOW
3126	BELLOW PLATE
3144-T-FC	.	LOOPER FRAME ASSEMBLY "51" CLASS FITTED COMPLETE
3410-51	..	FRONT ROCKER, COMPLETE "51" CLASS
3523	ROCKER PLATE
3535	BELLOW THRUST WASHER
3624	LOOPER SHAFT
3628	LOOPER HOLDER
3629	LOOPER SET SCREW
3752	ROCKER SCREW
3757	PIG TAIL, THREAD GUIDE

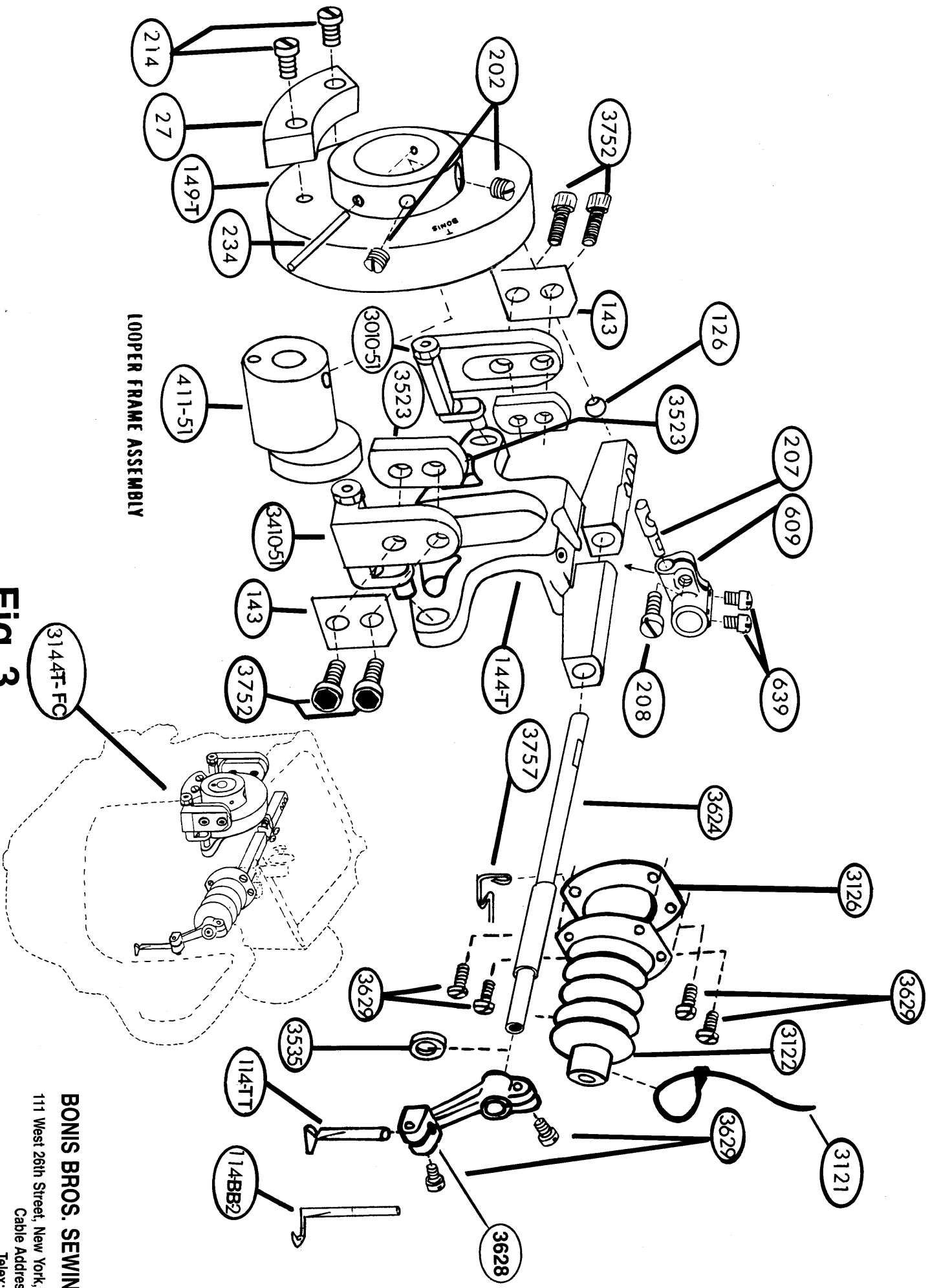

LOOPER FRAME ASSEMBLY

Fig. 3

BONIS BROS. SEWING MAC

111 West 26th Street, New York, N.Y. 10001

Cable Address: "BONIBF"

Telex: 422449

Fax: (212)645-0914

GEAR & FEED ASSEMBLY

Fig. 2

PART NO.	DESCRIPTION
17	FEED GEAR, SMALL
106-B	FEED DISC SHAFT
132	FEED DISC SHAFT SPRING
202	SET SCREW 6 REQ'D
203	STITCH INDICATOR SET SCREWS, 2 REQ'D
211	FEED DRIVING SCREW
416-S	FEED GEAR ONLY (STEEL)
419	FEED GEAR RING
420	FEED GEAR CAM
421	FEED GEAR ROLLER, 8 REQ'D
423	FEED GEAR ROLLER PIN, 8 REQ'D
424	FEED GEAR ROLLER SPRING, 8 REQ'D
426	FEED GEAR PLATE SCREW, 5 REQ'D
427	FEED GEAR CAM SCREW, 8 REQ'D
628	FEED RETAINING DRUM
629	FEED RETAINING DRUM CAM
630	FEED RETAINING DRUM PLATE
630-FC	FEED RETAINING DRUM COMPLETE, LEFT SIDE
3011	CONNECTING STUD
3012	ADJUSTABLE CLAMP
3013	STITCH REGULATOR
3014	FEED CONNECTION
3047	FEED DISC SHAFT BUSHING
3416-B-FC	FEED GEAR FITTED COMPLETE, RIGHT SIDE
3417	FEED GEAR SHAFT
3425-B	FEED GEAR PLATE
3755	FEED DISC SHAFT BUSHING SCREW
3761	DRUM PLATE SCREW

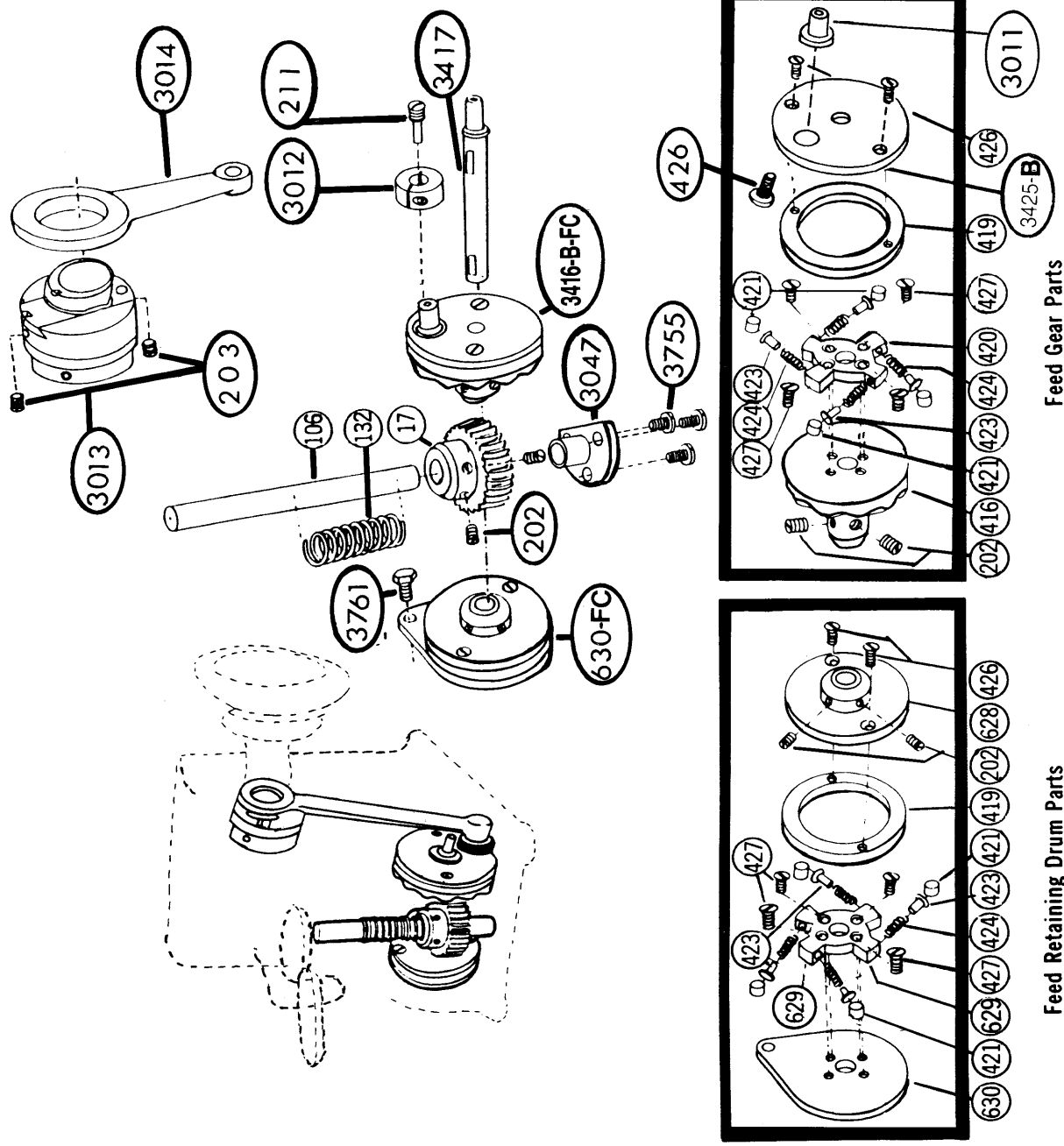

Feed Gear Parts

Feed Retaining Drum Parts

GEAR AND FEED ASSEMBLY

Fig. 2

NEEDLE BAR ASSEMBLY

Fig. 4

PART NO. DESCRIPTION

7-B-51	NEEDLE BAR YOKE ECCENTRIC "51" CLASS
113-T	NEEDLE BAR (T-R) ORDER BY MODEL NUMBER
115	NEEDLE BAR TENSION PLATE
119	NEEDLE CLAMP
134	NEEDLE BAR TENSION SPRING
202	YOKE ECCENTRIC SET SCREW-2 REQ'D
215	NEEDLE BAR TENSION PLUNGER
216	NEEDLE BAR PLUNGER NUT
217	NEEDLE BAR TENSION PLATE SCREW
218	NEEDLE BAR YOKE PINCH SCREW, 2 REQ'D
227	NEEDLE CLAMP SCREW
235	YOKE ECCENTRIC PIN
466-51	NEEDLE BAR YOKE "51" CLASS
467	NEEDLE BAR YOKE SUPPORT SHAFT
468	NEEDLE BAR YOKE SUPPORT SHAFT NUT
469	NEEDLE BAR YOKE ADJUSTABLE BRACKET
3617	NEEDLE BAR BUSHING, FRONT
3618	NEEDLE BAR BUSHING, REAR
3750	BACK SHAFT SCREW WASHER
3752	ROCKER SCREW-2 REQ'D
	NEEDLE SYSTEM 292 H BALL POINT OR F KNIFE POINT

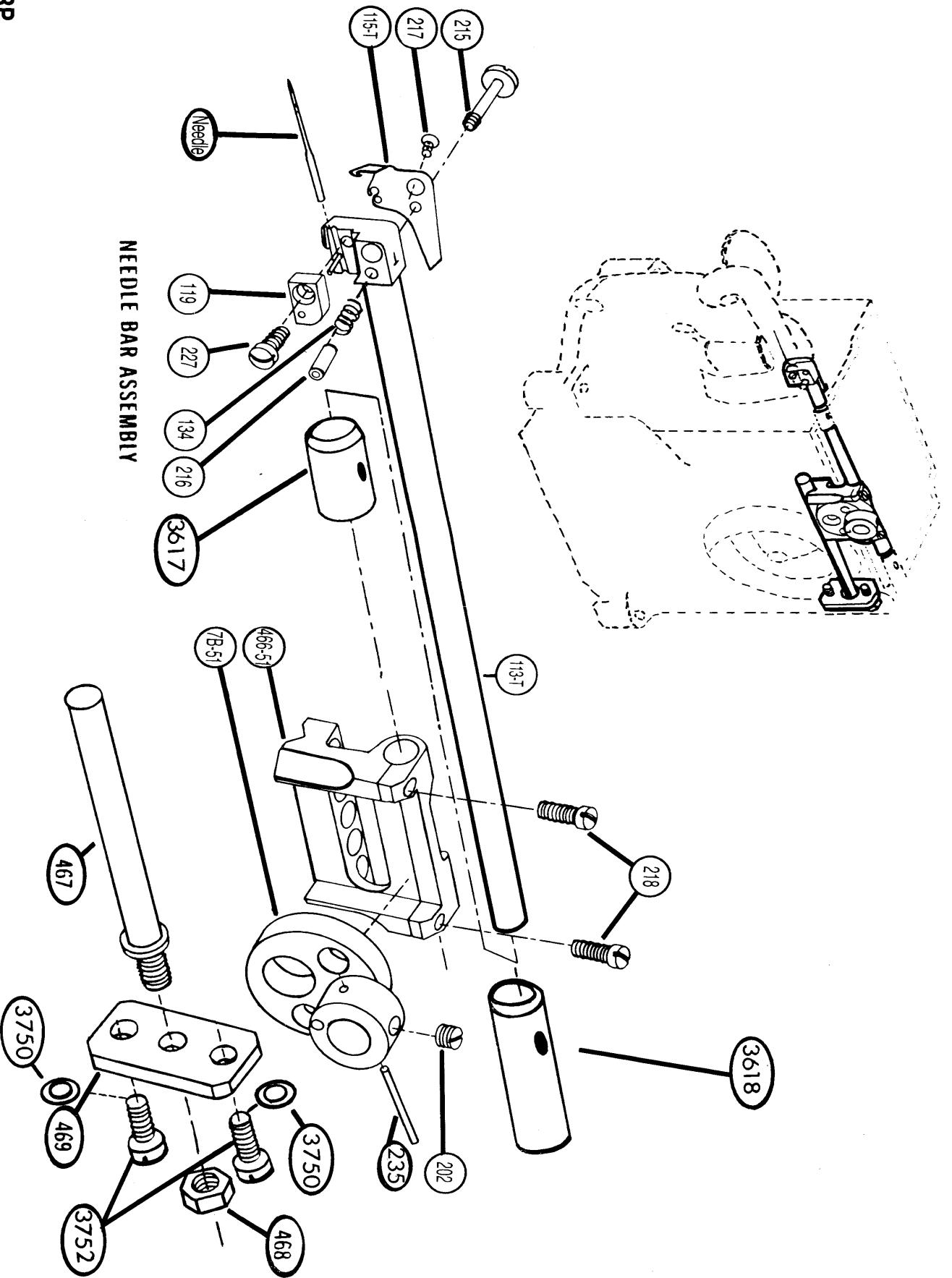

Fig. 4